



The **EDGE** Smart Design **Pallet Stackers**



EDGE Stacker
- EU Standard (Fork-over)
PSE12B/N



EDGE Stacker - Initial Lift
PSE12BD/ND



EDGE Stacker - Straddle Leg:
PSE12BSL/NSL



EDGE Stacker - Mono-Mast
PSE12BM/NM

Performance

NOBLELIFT
Material Handling

EDGE series

Pallet Truck:
Li-ion Powered 1.2T- 1.5T- 2.0T & AGM 2.0T

Pallet Stacker:
Li-ion or AGM Powered 1.2T, Lift height: up to 3.6m

Light Weight	Small Size	Low self-weight	Li Lithium battery
Smart design	CAN-bus	Best Cost-Performance Ratio	AGM
			CE

- PSE12B**
● 1.2T Capacity **AGM**
- Perfect for light-duty applications.
 - Compact & light service weight
 - High maneuverability
 - Maintenance-free Lead-acid Battery
 - Integrated on-board 12A charger
 - Ideal for use on mezzanines

- PSE12N**
● 1.2T Capacity **Li-ion**
- Perfect for light-duty applications.
 - Compact & light service weight
 - High maneuverability
 - Fast-charging Li-ion batteries.
 - Integrated on-board 25A charger
 - Ideal for use on mezzanines
 - Ultimate solution for light duty operations

Smart and Ergonomic Tillers

Standard For PSE12B and PSE12N



*PSE12BD/ND, PSE12BSL/NSL, PSE12BM/NM and PSE12B/N have the same tiller as standard, PSE12N, PSE12ND, PSE12NS, PSENM have the RFID card as standard.

Maintenance Friendly

Convenient and fast access to any component of the truck, no elements are located in areas difficult to reach. No Special tools are required.

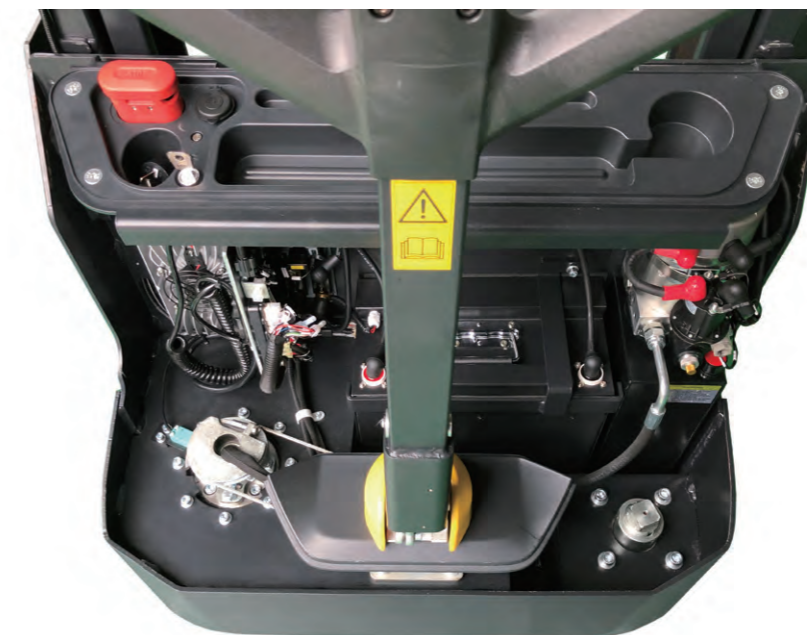

Capacity	Ready	Min Volt	Max Volt
17.6%	24.50V	0mV	0mV
	0.00A	Avg Volt	Communication
		0.0mV	Normal

Realtime			
Rated Capacity	60.0	Ah	Wh(Current)
Discharge Cycle ... Times			0.0
		Discharge Cycle ... Times	Wh
			<input type="button" value="Reset"/>

Other		
Name	Value	Units
Cell Temp1	25.3	C
Cell Temp1	25.1	C
SOC	45	1/255
Power Temp	27.1	C
Envir Temp	32.2	C
Cell Volt Alarm	none	
Total Volt Alarm	none	
Current Alarm	none	
Temp Alarm	none	
Balance Alarm	none	

Volt		
Name	Value	Units
Cell	3507	mV
Total	24.5	V
Current	0.0	A
Run(Wh)	0	Wh

The software diagnostic tool for lithium batteries can provide full information about battery's condition and its current status. (The above values are for reference only.)

Vertical Driving in Confined Space



The function of driving with tiller in the **vertical position** helps with work in confined area without sacrificing of safety.

The tiller bar is supported by the air spring which helps to return the tiller to its vertical position without strike in the end point.

For increase of operation comfort and safety the trucks are equipped with speed reduction function in turns.



Battery Management System

CAN-bus

The BMS of battery controls charging and discharging parameters, working temperature, short circuits, has sleeping mode and is able to turn off the power in case of emergency. Communication with BMS and software adjustment is possible via CAN



The electric system is using CAN communication protocol increasing reliability of the system.



PSE12B/BD/BSL/BM

2x12 85Ah (5Hr) AGM maintenance free batteries are used.

Optionally available 2x12 106Ah (5Hr).



For PSE12B the charger with current 12A is used. The standard charging time is 7 hours



PSE12N/ND/NSL/NM

24V 60Ah Lithium LiFePO4 battery with BMS. Lithium battery has connection terminals with screws and located inside the steel case



For PSE12N the charger with current 25A is used. The standard charging time is 2.5 hours. Opportunity charging is supported

The **PSE12N/ND/NSL/NM** stacker is equipped with maintenance-free 24V/60Ah LiFePO4 type Li-ion battery with fast charging and ultra-high number of charging /discharging cycles during life time; opportunity charging feature basically does not limit your operation time. The integrated BMS provides the same features as the BMS for the batteries of pallet trucks(refer to pallet truck section) .

The on-board charger with 25A current can provide full charge for less than 2.5 hours with great efficiency.

The **PSE12B/BD/BSL/BM** stacker is equipped with 2x12V 85Ah VRLA-AGM maintenance free batteries. Optionally available 2x12V 105Ah batteries for longer operation.

The stacker is equipped with 12A on-board charger. The charging time is 7-8 hours, opportunity charging is not available.



Smart Design with Compact Size and Perfect observation

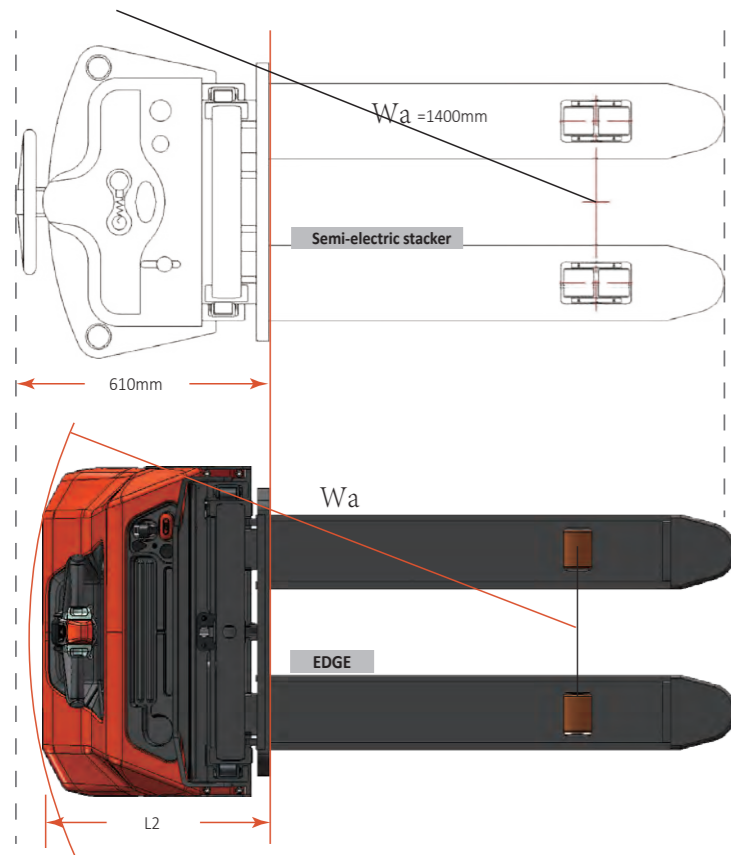

Model	length(L2)	Turning Radius
PSE12B/N	560mm	1350mm
PSE12BD/ND	602mm	1467/1384mm
PSE12BSL/NSL	640mm	1345mm
PSE12BM/NM	560mm	1350mm

Our engineers put a lot of efforts to achieve compactness of the trucks in comparison with traditionally used manual and semi-electric products without sacrificing of stability, robustness, safety and operation comfort.



Wide mast provides perfect observation of forks, the field of view is clear and not interrupted by mast sections, cylinder or chains. (Except PSE12BM/NM)



The operator can always clearly see the forks which significantly increases safety of operation



Robustness

Gradeability Performance

Mode	PSE12B/N/BD/ND/BM/NM	PSE12BSL/NSL
Max. grade ability laden	5%	4%
Max. grade ability unladen	10%	10%



Steel cover

The main cover is made out of steel with thickness 2.0mm



Tiller is made out of PA6 30% of glass fiber material, having high strength.

Capacity of 1200kg with high residual value at maximum height (load center distance 600 mm)

Real mast profiles are used for long life-time, no cheap bended solutions used. All directed to maintain performance of the truck during its life-cycle.



Welded forks are used to ensure robustness.

Standard configuration & options for EDGE family

PSE12B/N EDGE Stacker- EU Standard(Fork-over)

Mast table PSE 12B/PSE 12N

Designation	Lowered mast height h1 (mm)	Free lift height h2 (mm)	Lift height h3 (mm)	Extended mast height h4 (mm)	Lift + fork height h3 + h13(mm)
Single-stage mast	1930	1514	1514	1930	1600
	2330	1914	1914	2330	2000
Two-stage mast	1930	-	2814	3337	2900
	2080	-	3114	3637	3200
	2280	-	3514	4037	3600

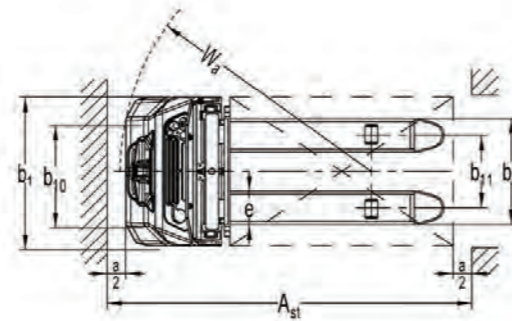
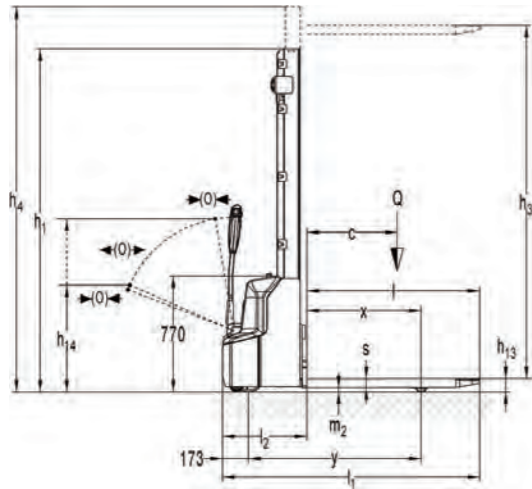

Type sheet for industrial truck acc. to VDI 2198

Distinguishing mark		PS E12B	PS E12N
1.2	Manufacturer`s type designation		3600
1.3	Power (battery ,diesel, petrol, gas, manual)		Battery
1.4	Operator type		Pedestrian
1.5	Load Capacity / rated load	Q (t)	1.2
1.6	Load centre distance	c (mm)	600
1.8	Load distance ,centre of drive axle to fork	x (mm)	760
1.9	Wheelbase	y (mm)	1147
Weight			
2.1	Service weight	kg	620
2.2	Axle loading, laden front/rear	kg	580 / 1240
2.3	Axle loading, unladen front/rear	kg	450 / 170
Tyres, chassis			
3.1	Tires		Polyurethane
3.2	Tire size,front	x w (mm)	Φ210×75
3.3	Tire size,rear	x w (mm)	Φ84×93
3.4	Additional wheels(dimensions)	x w (mm)	Φ100×50
3.5	Wheels,number front/rear(x=driven wheels)		1x + 1 / 2
3.6	Tread, front	b10 (mm)	550
3.7	Tread, rear	b11 (mm)	400 / 515
Dimensions			
4.2	Lowered mast height	h1 (mm)	2280
4.3	Free Lift height	h2 (mm)	—
4.4	Lift height	h3 (mm)	3514
4.5	Extended mast height	h4 (mm)	4037
4.9	Height of tiller in drive position min./ max.	h14 (mm)	710 / 1150
4.15	Height, lowered	h13 (mm)	86
4.19	Overall length	l1 (mm)	1710
4.20	Length to face of forks	l2 (mm)	560
4.21	Overall width	b1 (mm)	800
4.22	Fork dimensions	s/e/l (mm)	60 / 180 / 1150
4.25	Distance between fork-arms	b5 (mm)	570 / 685
4.32	Ground clearance, centre of wheelbase	m2 (mm)	26
4.33	Aisle width for pallets 1000X1200 crossways	Ast (mm)	2197
4.34	Aisle width for pallets 800X1200 lengthways	Ast (mm)	2145
4.35	Turning radius	Wa (mm)	1350
Performance Data			
5.1	Travel speed, laden/ unladen	km/h	4.5/ 4.7
5.2	Lift speed, laden/ unladen	m/s	0.11/ 0.14
5.3	Lowering speed, laden/ unladen	m/s	0.13 / 0.11
5.8	Max. gradeability, laden/ unladen	%	5 / 10
5.10	Service brake		Electromagnetic
Electric- engine			
6.1	Drive motor rating S2 60min	kW	0.65
6.2	Lift motor rating at S3 4.5%	kW	2.2
6.3	Battery acc. to DIN 43531/35/36 A, B, C, no		No
6.4	Battery voltage, nominal capacity K5	V / Ah	2x12/85 ¹⁾
6.5	Battery weight +/-5%	kg	2x27 ²⁾
6.6	Energy consumption acc: to VDI cycle	kWh/h	0.8
Additional data			
8.1	Type of drive control		DC
8.4	Sound level at driver`s ear acc. to EN 12053	dB(A)	<70

1) Option: 2x12V/106Ah
2) 2x12V/106Ah : 2 x 34kg

PSE12BD/ND EDGE Stacker - Initial Lift

Mast table PSE 12BD/PSE 12ND

Designation	Lowered mast height h1 (mm)	Free lift height h2 (mm)	Lift height h3 (mm)	Extended mast height h4 (mm)	Lift + fork height h3+h13 (mm)
Single-stage mast	1970	1514	1514	1970	1600
	2370	1914	1914	2370	2000
Two-stage mas	1820	-	2514	3077	2600
	1970	-	2814	3377	2900
	2120	-	3114	3637	3200
	2320	-	3514	4077	3600

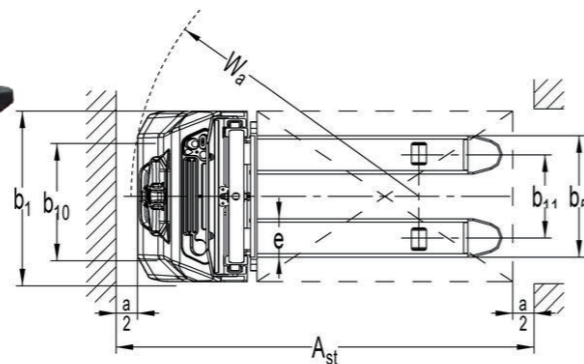
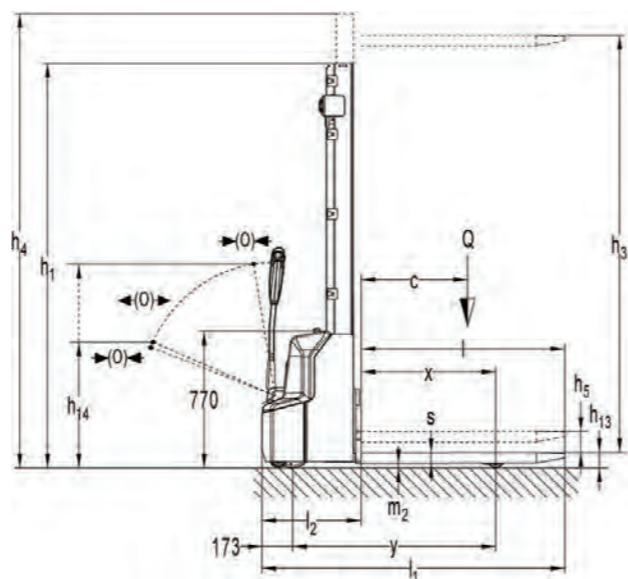

Distinguishing mark		PS E12BD	PS E12ND
1.2	Manufacturer's type designation		3600
1.3	Power (battery, diesel, petrol, gas, manual)		Battery
1.4	Operator type		Pedestrian
1.5	Load Capacity / rated load		1.2 ³⁾
	Mast lifting capacity	Q (t)	1.2
	Pallet lifting capacity		1.2
1.6	Load centre distance	x (mm)	600
1.8	Load distance, centre of drive axle to fork	c (mm)	835/752 ⁴⁾
1.9	Wheelbase	y (mm)	1264/1181 ³⁾
Weight			
2.1	Service weight	kg	700
2.2	Axle loading, laden front/rear	kg	680 / 1220
2.3	Axle loading, unladen front/rear	kg	505 / 195
Tyres, chassis			
3.1	Tires		Electromagnetic
3.2	Tire size, front	x w (mm)	Φ210×75
3.3	Tire size, rear	x w (mm)	Φ84×93
3.4	Additional wheels(dimensions)	x w (mm)	Φ100×50
3.5	Wheels, number front/rear(x=driven wheels)		1x + 1 / 2
3.6	Tread, front	b10 (mm)	550
3.7	Tread, rear	b11 (mm)	400 / 515
Dimensions			
4.2	Lowered mast height	h1 (mm)	2320
4.3	Free Lift height	h2 (mm)	—
4.4	Lift height	h3 (mm)	3514
4.5	Extended mast height	h4 (mm)	4077
4.6	Initial lift	h5 (mm)	120
4.9	Height of tiller in drive position min./ max.	h14 (mm)	710/1150
4.15	Height, lowered	h13 (mm)	90
4.19	Overall length	l1 (mm)	1752
4.20	Length to face of forks	l2 (mm)	602
4.21	Overall width	b1 (mm)	800
4.22	Fork dimensions	s/e/l (mm)	60 / 180/1150
4.25	Distance between fork-arms	b5 (mm)	570/685
4.32	Ground clearance, centre of wheelbase	m2 (mm)	24
4.33	Aisle width for pallets 1000X1200 crossways	Ast (mm)	2290/2234 ⁴⁾
4.34	Aisle width for pallets 800X1200 lengthways	Ast (mm)	2209/2185 ⁴⁾
4.35	Turning radius	Wa (mm)	1467/1384 ⁴⁾
Performance Data			
5.1	Travel speed, laden/ unladen	km/h	4.2/ 4.5
5.2	Lift speed, laden/ unladen	m/s	0.11 / 0.14
5.3	Lowering speed, laden/ unladen	m/s	0.13 / 0.11
5.8	Max. gradeability, laden/ unladen	%	5 / 10
5.10	Service brake		Electromagnetic
Electric- engine			
6.1	Drive motor rating S2 60min	kW	0.65
6.2	Lift motor rating at S3 4.5%	kW	2.2
6.3	Battery acc. to DIN 43531/35/36 A, B, C, no		No
6.4	Battery voltage, nominal capacity K5	V / Ah	2x12/85 ¹⁾
6.5	Battery weight +/-5%	kg	2x27 ²⁾
6.6	Energy consumption acc: to VDI cycle	kWh/h	0.66
Additional data			
8.1	Type of drive control		DC
8.4	Sound level at driver's ear acc. to EN 12053	dB(A)	<70

1) Option: 2x12V/106Ah(AGM).

3) When we operate the two layers: Mast lifting capacity < Pallet lifting capacity

2) 2x12V/106Ah: 2x34kg

4) No initial lift/Initial lift

PSE12BSL/NSL EDGE Stacker - Straddle Legs

Mast table PSE 12B/SLPSE 12NSL

Designation	Lowered mast height h1 (mm)	Free lift height h2 (mm)	Lift height h3 (mm)	Extended mast height h4 (mm)	Lift + fork height h3+h13 (mm)
Single-stage mast	1940	1514	1514	2064	1564
	2340	1914	1914	2464	1964
Two-stage mast	1790	-	2514	3064	2564
	1940	-	2814	3364	2864
	2090	-	3114	3664	3164
	2290	-	3514	4064	3564

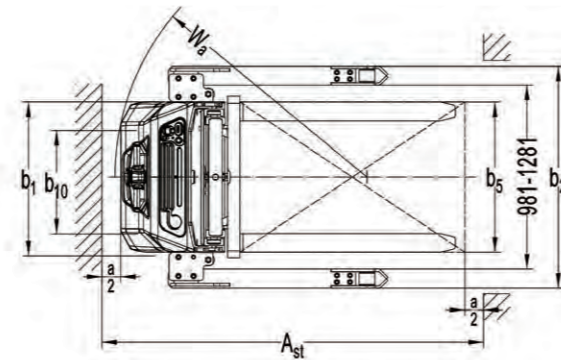
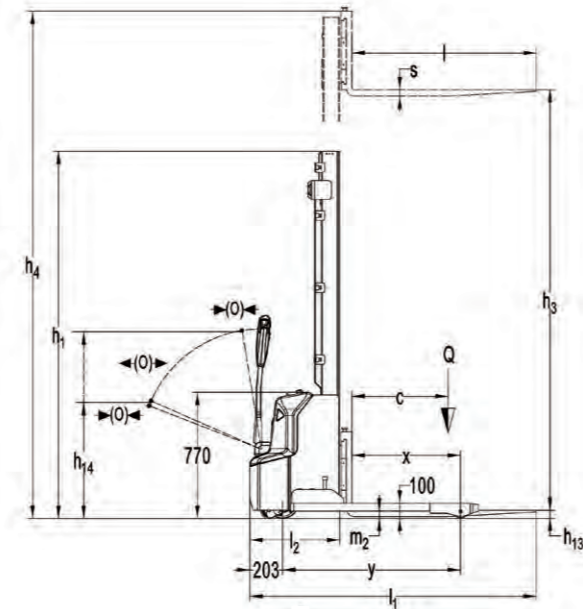

Type sheet for industrial truck acc. to VDI 2198)

Distinguishing mark		PSE12BSL	PSE12NSL
1.2	Manufacturer's type designation		3600
1.3	Power (battery, diesel, petrol, gas, manual)		Battery
1.4	Operator type		Pedestrian
1.5	Load Capacity / rated load	Q (t)	1.2
1.6	Load centre distance	c (mm)	600
1.8	Load distance, centre of drive axle to fork	x (mm)	674
1.9	Wheelbase	y (mm)	1111
Weight			
2.1	Service weight	kg	860
2.2	Axle loading, laden front/rear	kg	760 / 1300
2.3	Axle loading, unladen front/rear	kg	650 / 210
Tyres, chassis			
3.1	Tires		Polyurethane
3.2	Tire size, front	x w (mm)	Φ210×75
3.3	Tire size, rear	x w (mm)	Φ84×93
3.4	Additional wheels (dimensions)	x w (mm)	Φ100×40
3.5	Wheels, number front/rear (x=driven wheels)		1x + 2 / 2
3.6	Tread, front	b10 (mm)	520
Dimensions			
4.2	Lowered mast height	h1 (mm)	2290
4.3	Free Lift height	h2 (mm)	—
4.4	Lift height	h3 (mm)	3514
4.5	Extended mast height	h4 (mm)	4064
4.9	Height of tiller in drive position min./ max.	h14 (mm)	710 / 1150
4.15	Height, lowered	h13 (mm)	60
4.19	Overall length	l1 (mm)	1790
4.20	Length to face of forks	l2 (mm)	640
4.21	Overall width	b1/b2 (mm)	800/(1181/1281/1381/1481)
4.22	Fork dimensions	s/e/l (mm)	40 / 100 / 1150
4.25	Distance between fork-arms	b5 (mm)	252-800
4.32	Ground clearance, centre of wheelbase	m2 (mm)	40
4.33	Aisle width for pallets 1000X1200 crossways	Ast (mm)	2228
4.34	Aisle width for pallets 800X1200 lengthways	Ast (mm)	2206
4.35	Turning radius	Wa (mm)	1345
Performance Data			
5.1	Travel speed, laden/ unladen	km/h	4.2/ 4.5
5.2	Lift speed, laden/ unladen	m/s	0.11 / 0.14
5.3	Lowering speed, laden/ unladen	m/s	0.13 / 0.11
5.8	Max. gradeability, laden/ unladen	%	4 / 10
5.10	Service brake		Electromagnetic
Electric- engine			
6.1	Drive motor rating S2 60min	kW	0.65
6.2	Lift motor rating at S3 4.5%	kW	2.2
6.3	Battery acc. to DIN 43531/35/36 A, B, C, no		No
6.4	Battery voltage, nominal capacity K5	V / Ah	2x12/85 ¹⁾
6.5	Battery weight +/-5%	kg	2x27 ²⁾
6.6	Energy consumption acc: to VDI cycle	kWh/h	0.6
Additional data			
8.1	Type of drive control		DC
8.4	Sound level at driver's ear acc. to EN 12053	dB(A)	<70

1) Option: 2x12V/106Ah
2) 2x12V/106Ah: 2x34kg

PSE12BM/NM EDGE Stacker-Mono-Mast

Mast table PSE 12BM/PSE 12NM

Designation	Lowered mast height h1 (mm)	Free lift height h2 (mm)	Lift height h3 (mm)	Extended mast height h4 (mm)	Lift + fork height h3+h13 (mm)
Single-stage mast	1130	714	1514	1130	800
	1930	1514	1914	1930	1600
	2330	1914	2514	2330	2000

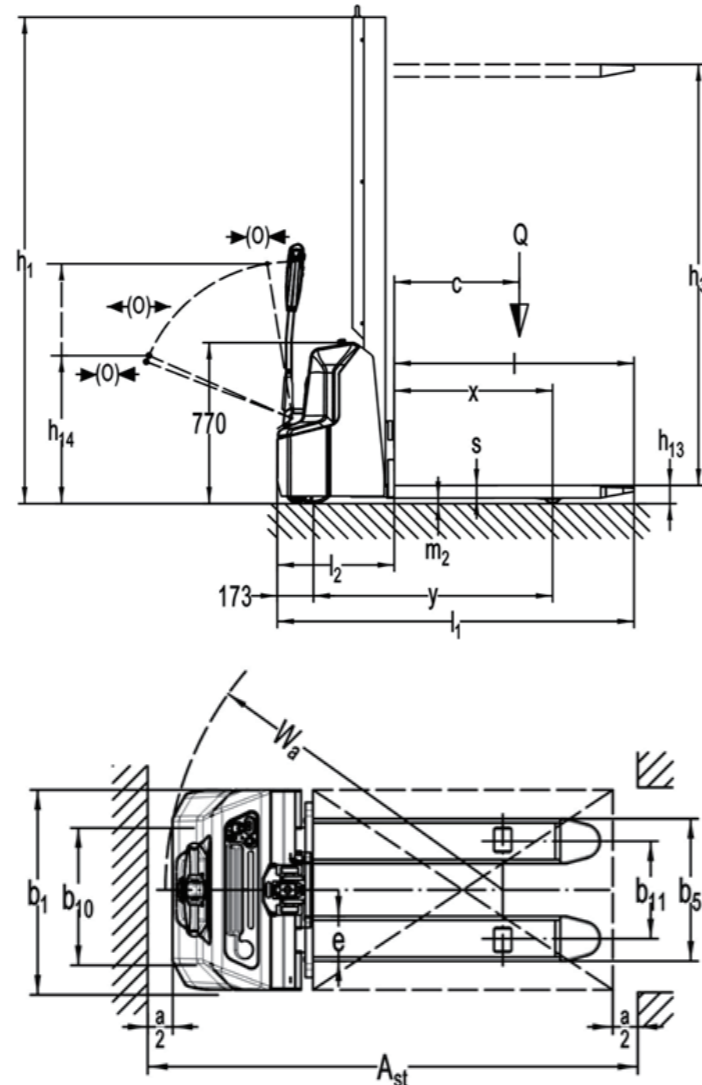
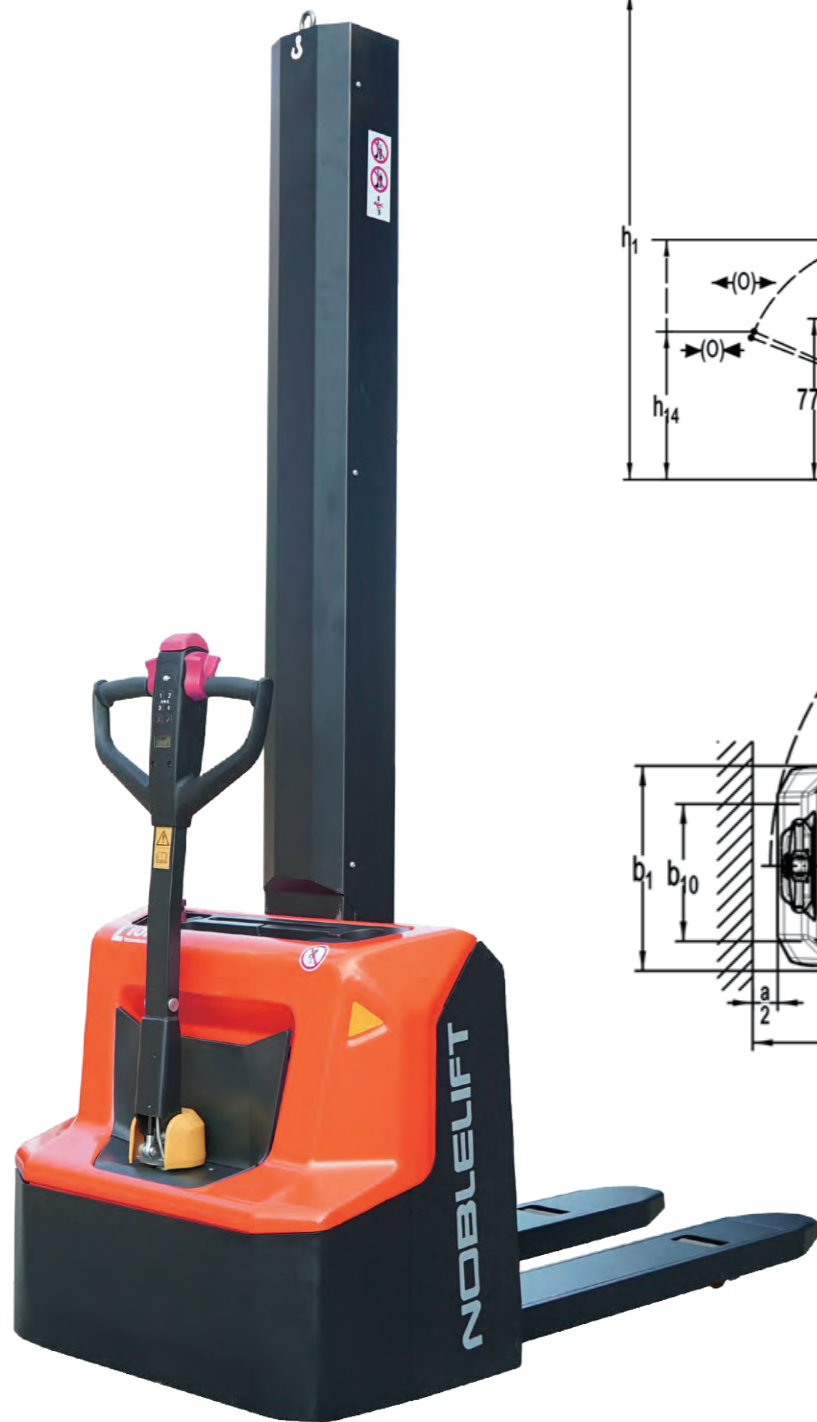

Type sheet for industrial truck acc. to VDI 2198

Distinguishing mark		PSE12BM	PSE12NM
1.2	Manufacturer's type designation		2000
1.3	Power (battery, diesel, petrol, gas, manual)		Battery
1.4	Operator type		Pedestrian
1.5	Load Capacity / rated load	Q (t)	1.2
1.6	Load centre distance	c (mm)	600
1.8	Load distance, centre of drive axle to fork	x (mm)	760
1.9	Wheelbase	y (mm)	1147
Weight			
2.1	Service weight	kg	530
2.2	Axle loading, laden front/rear	kg	500 / 1230
2.3	Axle loading, unladen front/rear	kg	375 / 155
Tyres, chassis			
3.1	Tires		Polyurethane
3.2	Tire size, front	x w (mm)	Φ210×75
3.3	Tire size, rear	x w (mm)	Φ84×93
3.4	Additional wheels (dimensions)	x w (mm)	Φ100×50
3.5	Wheels, number front/rear (x=driven wheels)		1x + 1 / 2
3.6	Tread, front	b10 (mm)	550
3.7	Tread, rear	b11 (mm)	400
Dimensions			
4.2	Lowered mast height	h1 (mm)	2330
4.3	Free Lift height	h2 (mm)	1914
4.4	Lift height	h3 (mm)	1914
4.9	Height of tiller in drive position min./ max.	h14 (mm)	710 / 1150
4.15	Height, lowered	h13 (mm)	86
4.19	Overall length	l1 (mm)	1710
4.20	Length to face of forks	l2 (mm)	560
4.21	Overall width	b1 (mm)	800
4.22	Fork dimensions	s/e/l (mm)	60 / 180 / 1150
4.25	Distance between fork-arms	b5 (mm)	570
4.32	Ground clearance, centre of wheelbase	m2 (mm)	24
4.33	Aisle width for pallets 1000X1200 crossways	Ast (mm)	2197
4.34	Aisle width for pallets 800X1200 lengthways	Ast (mm)	2145
4.35	Turning radius	Wa (mm)	1350
Performance Data			
5.1	Travel speed, laden/ unladen	km/h	4.2/ 4.5
5.2	Lift speed, laden/ unladen	m/s	0.11 / 0.14
5.3	Lowering speed, laden/ unladen	m/s	0.13 / 0.11
5.8	Max. gradeability, laden/ unladen	%	5 / 10
5.10	Service brake		Electromagnetic
Electric- engine			
6.1	Drive motor rating S2 60min	kW	0.65
6.2	Lift motor rating at S3 4.5%	kW	2.2
6.3	Battery acc. to DIN 43531/35/36 A, B, C, no		No
6.4	Battery voltage, nominal capacity K5	V / Ah	2x12/85 ²⁾
6.5	Battery weight +/-5%	kg	2x27 ³⁾
6.6	Energy consumption acc: to VDI cycle	kWh/h	0.8
Additional data			
8.1	Type of drive control		DC
8.4	Sound level at driver's ear acc. to EN 12053	dB(A)	<70

1) Including the ring screw: +55mm.

2) Option: 2x12V/106Ah.

3) 2x12V/106Ah: 2x34kg.