

FE3R16NC

Three-wheel Rear Drive Forklift

Ready for Lithium power

ADVANTAGES

- Smart & Compact Design with Great Mobility
- Maintenance-free AC Drive System
- Intelligent Computer Controller System
- On-board Self-Diagnostic Display
- Excellent Safety and Reliability
- Easy Service & Maintenance
- Standard Side Battery Extraction
- Great Comfort and Ergonomic Design
- Easy EPS Steering (for FE3R16N)

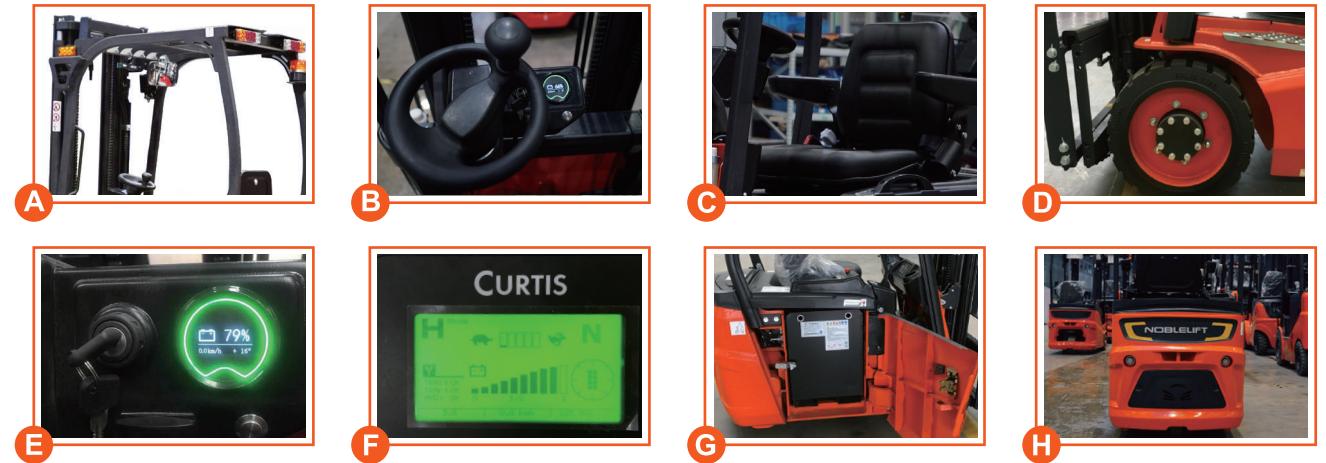
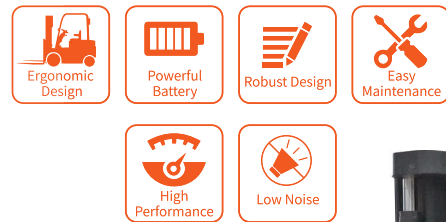

- A** Front LED Lights, Steering lights, Rear Combination Lights, Warning light standard, safe to work in dark environment such as containers or in the night.
- B-C** Small Diameter Steering Wheel with Spinner Knob, Adjustable Steering wheel position and seat to optimize the comfortness of the operator for long time operation.
- D** Small Diameter Solid Front Wheels for easy and smooth motion.
- E-F** Intelligent ZAPI or Curtis Self-diagnostic display for easy operation and maintenance, Standard Rear Wheel Position Sensor & Display with Speed Reduction at Turning.
- G** Optional different battery capacities for different operation needs, optional Aquamatic battery self-filling system for easy battery maintenance.
- H** Extremely compact design with small width and turning radius for easy operation in confined spaces.



Vehicle width 1000mm, turning radius 1500mm, so that the vehicle has a good passability.



Battery compartment with fork pockets for 16N.

Electric Forklift

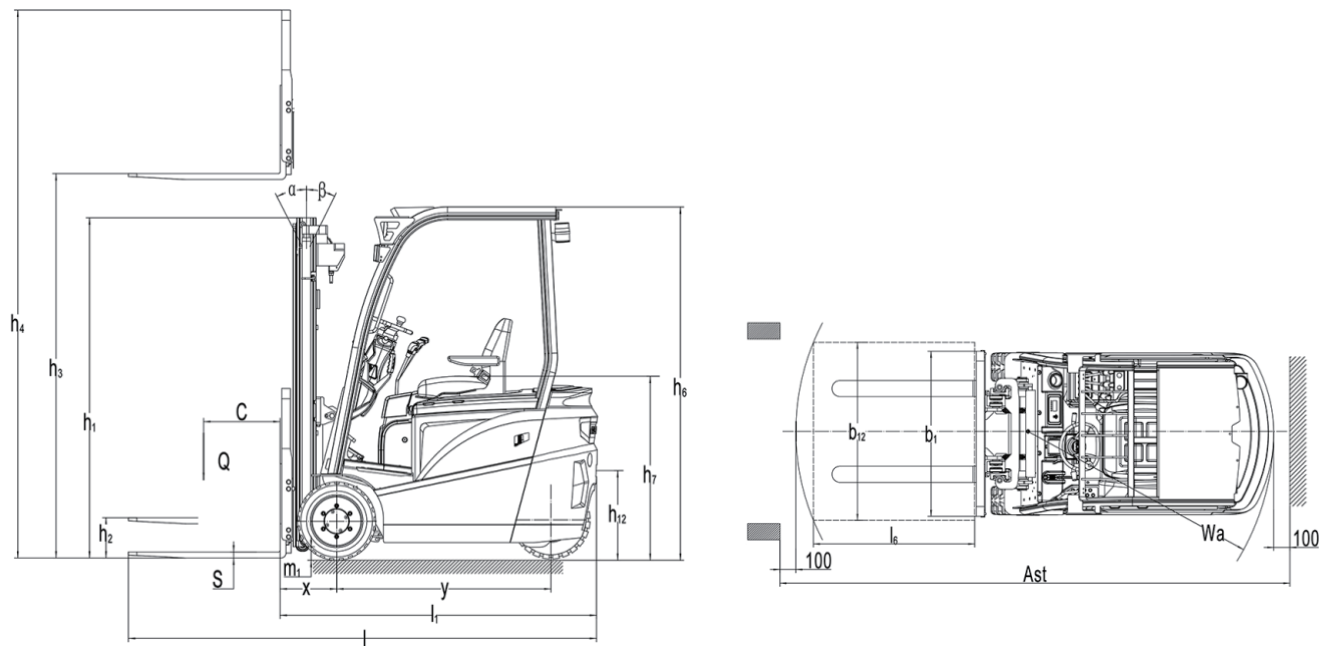

Mast Table FE3R16NC

Designation	Lift height h3 (mm)	Free Lift h2 (mm)	Closed mast height h1 (mm)	Extended mast height h4 (mm)	Tilt forward/ backward $\alpha/\beta(^{\circ})$	Capacity table(kg) C=500mm without sideshift,single solid tyres FE3R16NC
Two-stage ZT	2500	105	1747	3480	4/4	1600
	2700	105	1847	3680	4/4	1600
	3000	105	1997	3980	4/4	1600
	3300	105	2147	4280	4/4	1600
	3500	105	2247	4480	4/4	1600
	3700	105	2347	4680	4/4	1500
	4000	105	2547	4980	4/4	1450
	4300	105	2697	5280	4/4	1350
Two-stage ZZ	4500	105	2797	5480	4/4	1250
	5000	105	3072	5980	4/4	1150
	2500	792	1747	3494	4/4	1600
	2700	892	1847	3694	4/4	1600
	3000	1042	1997	3994	4/4	1600
	3300	1192	2147	4294	4/4	1600
	3500	1292	2247	4494	4/4	1600
	3700	1392	2347	4694	4/4	1500
Three-stage DZ	4000	1592	2547	4994	4/4	1450
	4300	1742	2697	5294	4/4	1400
	4500	1842	2797	5494	4/4	1350
	4000	1386	1934	4974	4/4	1500
	4350	1510	2059	5322	4/4	1400
	4500	1560	2109	5472	4/4	1300
	4800	1660	2209	5772	4/4	1200
	5000	1760	2309	5972	4/4	1150
5500	1910	2459	6472	4/4	1050	
6000	2110	2659	6979	4/4	950	

Type sheet for industrial truck acc. to VDI 2198

1KG=2.2LB 1INCH=25.4MM

Identification		
1.2	Manufacturer's type designation	FE3R16NC
1.3	Drive:electric(battery or mains),diesel,petrol gas,manual)	electric
1.4	Type of operation(hand,pedestrian,standing,seated,order-picker)	seated
1.5	Load capacity/rated load	Q(kg) 1600
1.6	Load centre distance	c(mm) 500
1.8	Load distance,centre of drive axle to fork	x(mm) 340
1.9	wheelbase	y(mm) 1220
Weights		
2.1	Service weight incl. battery	kg 3000
2.2	Axle loading ,laden front/rear	kg 4000/600
2.3	Axle loading,unladen front/rear	kg 1280/1720
Wheels, Chassis		
3.1	Type:solid rubber,superelastic,pneumatic,polyurethane	solid rubber/solid rubber
3.2	Tyres size,front	18x7-8
3.3	Tyres size,rear	18x7-8
3.5	Wheels,number front/rear(x=driven wheels)	2/1x
3.6	Track width,front	b10(mm) 838
3.7	Track width,rear	b11(mm) /
Basic Dimensions		
4.1	Mast/fork carriage tilt forward/backward	$\alpha/\beta(^{\circ})$ 4/4
4.2	lowered mast height	h1(mm) 1997
4.3	Free lift	h2(mm) 105
4.4	Lift height	h3(mm) 3000
4.5	Extended mast height	h4(mm) 3980
4.7	Overhead load guardheight	h6(mm) 2110
4.8	Seat height/standing height	h7(mm) 1050
4.12	Coupling height	h10(mm) 570
4.19	Overall length	l1(mm) 2750
4.20	Length to face of forks	l2(mm) 1830
4.21	Overall width	b1(mm) 1000
4.22	Fork dimensions	s/e/l(mm) 35/100/920
4.24	Fork carriage width	b3(mm) 980
4.31	Ground clearance ,laden,under mast	m1(mm) 92
4.32	Ground clearance,centre of wheelbase	m2(mm) 97
4.33	Aisle width for pallets 1000x1200 crossways	Ast(mm) 3169
4.34	Aisle width for pallets 800x1200 lengthways	Ast(mm) 3292
4.35	Turning radius	Wa(mm) 1500
Performance Data		
5.1	Travel speed,laden/unladen	km/h 10/11
5.2	Lift speed,laden/unladen	m/s 0.30/0.40
5.3	lowering speed,laden/unladen	m/s <0.6
5.5	Drawbar pull,laden/unladen S2 60 min	N 2800/8000
5.7	Max.Gradient performance,laden/unladen S2 5 min	% 10/13
5.10	Service brake	hydraulic
E-Motor		
6.1	Drive motor rating S2 60 min	kW 5
6.2	Lift motor rating at S3 15%	kW 7
6.3	Battery standard	BS
6.4	Battery voltage,nominal capacity K5	V/Ah 48/350 48V/400(Optional)
6.4	Battery weight	kg 650
6.4	Battery dimensions l/w/h	mm 770x485x661
Other Details		
8.1	Type of drive control	AC
8.2	Operating pressure for attachments	Mpa 16
8.3	Oil volume for attachments	l/min 30
8.4	Sound level at driver's ear according to EN 12 053	dB(A) 70

Electric Forklift